

VCM

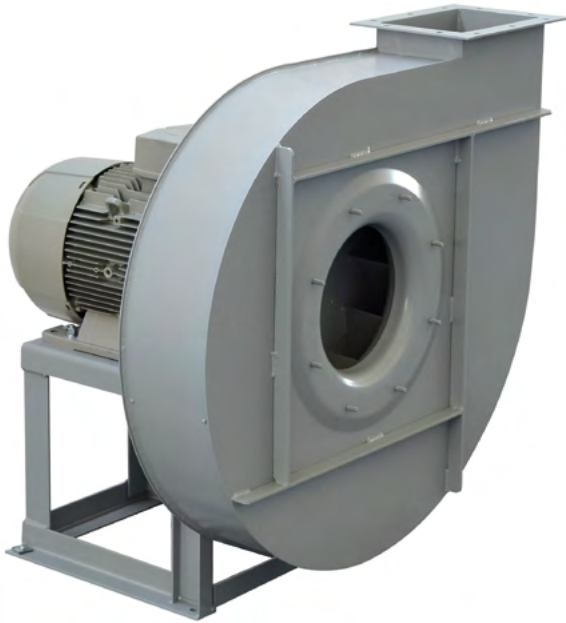

Rodete de álabes curvados hacia atrás
 Backward curved impeller

Ventilador centrífugo de acoplamiento directo y simple aspiración. Fabricados en chapa de acero protegida contra la corrosión mediante tratamiento por cataforesis + pintura poliuretana. Temperaturas del aire a transportar -20°C/+100°C en continuo.

Motores

De 2, 4 o 6 polos, de alta eficiencia IE 3*, tensión de alimentación trifásica 230/400V 50Hz tamaño motor 112 y 400/690V 50Hz para motores de mayor dimensión. Protección IP55, Clase F.

* A partir de 0,75 kW el motor puede ser de eficiencia IE 2 controlado por convertidor de frecuencia.

Bajo pedido

- Fabricación en diferentes materiales constructivos.
- Motores de 2 velocidades.
- Versiones de 60 Hz.
- Pintura en diferentes RAL.
- Versión sin pie soporte (Motor-Brida, Sistema 5), hasta tamaño de motor 160.
- Versión para alta temperatura: hasta 220°C (versiones B: con rodete de refrigeración).
- SISTEMA 8: acoplamiento mediante junta elástica.

Direct drive, single inlet centrifugal fan. Manufactured from steel sheet protected with cataforesis primer + polyurethane paint finish. Designed to continuously circulate air from -20°C up to 100°C.

Motors

2, 4 or 6 pole, IE 3* high efficiency, three-phase 230/400V 50Hz up to motor size 112 and 400/690V 50Hz for higher motors. IP55, Class F protection.

* From 0,75kW, motor can be IE 2 and controlled by VSD.

On request

- Manufactured from different materials.
- 2-speed motors.
- 60 Hz versions.
- Painted in different RAL colour.
- Fan with no supporting stand (Motor-Flange, Arrangement 5), up to motor size 160.
- High-temperature versions (up to 220°C) (B versions: with cooling impeller).
- ARRANGEMENT 8: with joint flexible coupling.

- Trampilla de inspección, purga de drenaje, distintos tipos de estanqueidad a nivel de voluta y de paso de eje.
- Ventiladores estancos.
- Calorifugado.

Versiones ATEX

Bajo pedido, versiones antiexplosivas según la Directiva ATEX para modelos trifásicos:

Para trabajar a temperaturas de -20°C a +60°C, presión ambiente (absoluta) de 0,8 bar hasta 1,1 bar, según EN 14986.

• Gas:

- ⊗ 2G IIB T2-T3-T4
- ⊗ 2G IIB+H2 T2-T3-T4
- ⊗ 3G IIB T2-T3-T4
- ⊗ 3G IIB+H2 T2-T3-T4

• Polvo no conductivo:

- ⊗ 2D IIIB T125°C-T135°C-T195°C-T295°C
- ⊗ 3D IIIB T125°C-T135°C-T195°C-T295°C

• Polvo conductivo (con motor IP65 IIIC):

- ⊗ 2D IIIC T125°C-T135°C-T195°C-T295°C
- ⊗ 3D IIIC T125°C-T135°C-T195°C-T295°C

- Inspection door, draining, different seals on scroll and shaft access.
- Welded casing.
- Thermal insulation lagging.

ATEX versions

On request, explosion proof versions in accordance with ATEX directive for three phase models: Ambient temperature -20°C to +60°C, ambient pressure (abs.) 0,8 bar to 1,1 bar according to EN 14986.

• Gas:

- ⊗ 2G IIB T2-T3-T4
- ⊗ 2G IIB+H2 T2-T3-T4
- ⊗ 3G IIB T2-T3-T4
- ⊗ 3G IIB+H2 T2-T3-T4

• Non-conductive dust:

- ⊗ 2D IIIB T125°C-T135°C-T195°C-T295°C
- ⊗ 3D IIIB T125°C-T135°C-T195°C-T295°C

• Conductive dust (compulsory IP65 IIIC motor):

- ⊗ 2D IIIC T125°C-T135°C-T195°C-T295°C
- ⊗ 3D IIIC T125°C-T135°C-T195°C-T295°C

CUADRO DE APLICACIONES TABLE OF APPLICATIONS	
Aire a transportar Air Type	Cantidad de polvo Dust quantity (mg/m ³)
Polvoriento (ambiente industrial) Medium dust (industrial environment)	<500

RODETE ÁLABES CURVADOS HACIA ATRÁS - ACOPLAMIENTO DIRECTO

BACKWARD CURVED IMPELLER - DIRECT DRIVE



CARACTERÍSTICAS TÉCNICAS / TECHNICAL FEATURES

Es imprescindible comprobar que las características eléctricas (voltaje, intensidad, frecuencia, etc.) del motor que aparecen en la placa del mismo son compatibles con las de la instalación.

Please, check that electrical features (voltage, current, frequency, etc.) are suitable with your installation.

Modelo Model	Tamaño motor Motor size	Velocidad Speed (r.p.m.)	Potencia motor Motor power (kW)	Intensidad motor 400V Maximum absorbed current 400V (A)	Caudal máximo Maximum airflow (m ³ /h)	Nivel presión sonora a 1 m Sound pressure level at 1 m (dB(A)) ⁽¹⁾	Peso Weight (kg) ⁽²⁾	Momento de inercia Moment of inertia (kg·m ²) ⁽³⁾
2 POLOS / 2 POLE								
VCM 352/2 N4A	80A2	2830	0,75	1,59	1.330	68	34	0,07
VCM 351/2 N4A	80B2	2850	1,10	2,33	1.650	69	38	0,08
VCM 402/2 N4A	90S2	2840	1,50	3,07	1.910	73	50	0,11
VCM 401/2 N4A	90L2	2890	2,20	4,43	2.690	74	54	0,13
VCM 452/2 N4A	100LA2	2900	3,00	5,77	2.700	76	65	0,20
VCM 451/2 N4A	112M2	2910	4,00	7,50	3.490	77	81	0,24
VCM 502/2 N4A	112M2	2910	4,00	7,50	3.420	79	96	0,33
VCM 501/2 N4A	132SA2	2890	5,50	10,10	4.720	85	109	0,38
VCM 562/2 N4A	132SB2	2890	7,50	13,90	4.750	85	136	0,55
VCM 561/2 N4A	160MR2	2935	11,00	18,70	6.720	86	144	0,65
VCM 632/2 N4A	160M2	2935	15,00	25,40	6.840	87	196	0,85
VCM 631/2 N4A	160L2	2935	18,50	33,30	9.390	88	209	1,05
VCM 712/2 N4A	180M2	2940	22,00	39,00	8.500	90	280	1,60
VCM 711/2 N4A	200L2	2960	30,00	53,50	13.530	91	400	2,00
VCM 802/2 N4A	200L2	2960	37,00	65,60	12.060	91	439	2,80
VCM 801/2 N4A	250M2	2960	55,00	93,50	19.450	92	554	3,50
VCM 902/2 N4A	280S2	2960	75,00	126,00	19.080	92	806	4,30
VCM 901/2 N4A	280M2	2960	90,00	151,00	27.910	93	845	5,00
VCM 1002/2 N4A	315S2	2970	110,00	186,00	21.600	93	1.090	8,00
VCM 1001/2 N4A	315M62	2970	160,00	263,00	38.490	94	1.120	9,50
4 POLOS / 4 POLE								
VCM 712/4 N4A	112M4	1425	4,00	8,2	4.120	70	190	1,60
VCM 711/4 N4A	132SA4	1440	5,50	10,3	6.580	71	200	2,00
VCM 802/4 N4A	132MA4	1450	7,50	13,9	5.910	73	290	2,80
VCM 801/4 N4A	132MB4	1460	9,20	17,4	9.590	74	295	3,50
VCM 902/4 N4A	160M4	1460	11,00	20,7	9.350	74	460	4,30
VCM 901/4 N4A	160L4	1450	15,00	28,4	13.670	78	470	5,00
VCM 1002/4 N4A	180M4	1470	18,50	34,9	10.690	80	590	8,00
VCM 1001/4 N4A	180L4	1470	22,00	40,9	19.050	81	630	9,50

¹ Entubado en la descarga / Piping only on outlet side

² Tolerancia del nivel de ruido de +3dB/A, medido en el punto de máxima eficiencia / Noise level tolerance +3 dB/A, measured in the maximum efficiency point

³ Con motor incluido y para orientación LG270 o RD270 / With motor included and for LG270 or RD270 position

³ Momento de inercia del rodetes / Impeller's moment of inertia

CURVAS CARACTERÍSTICAS (a la descarga) / PERFORMANCE CURVES (at outlet)

- Ventiladores ensayados con la aspiración y la descarga entubadas. - Fan ducted on both inlet and outlet sides.
- Caudal en m³/h. - Air volume in m³/h.
- **Psf: Presión estática en Pa.** - **Psf: Static pressure in Pa.**
- Modelo - Potencia motor en kW. - Model - Motor power in kW.
- Ejemplo: 561 - 11 - Example: 561 - 11
- Modelo - kW Model - kW

2 polos - Modelos desde 352 hasta 561
 2 pole - Models from 352 to 561

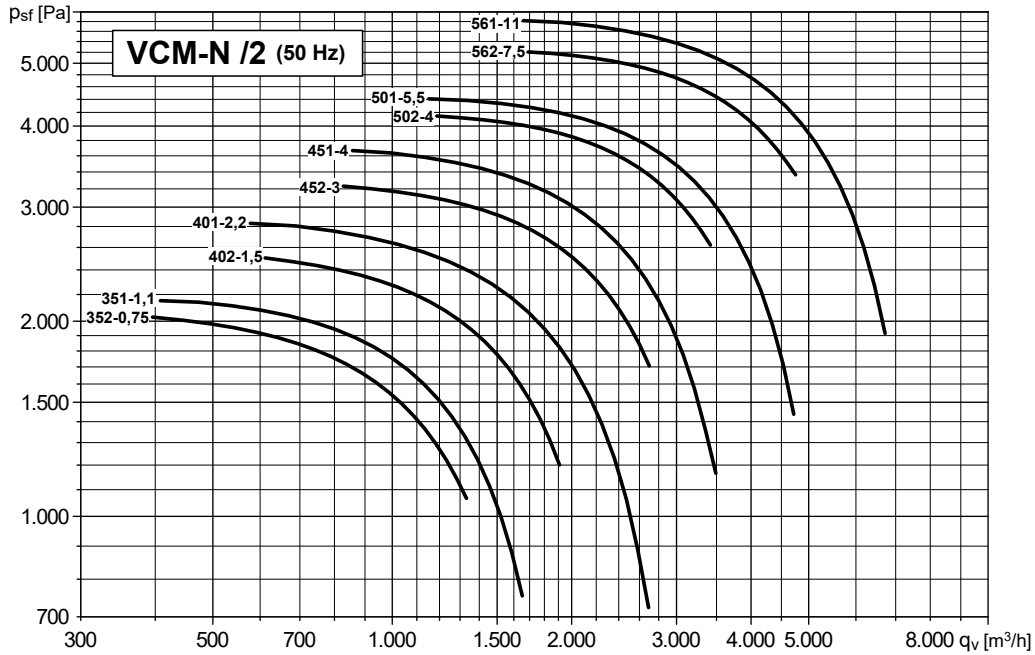

2 polos - Modelos desde 632 hasta 1001
 2 pole - Models from 632 to 1001

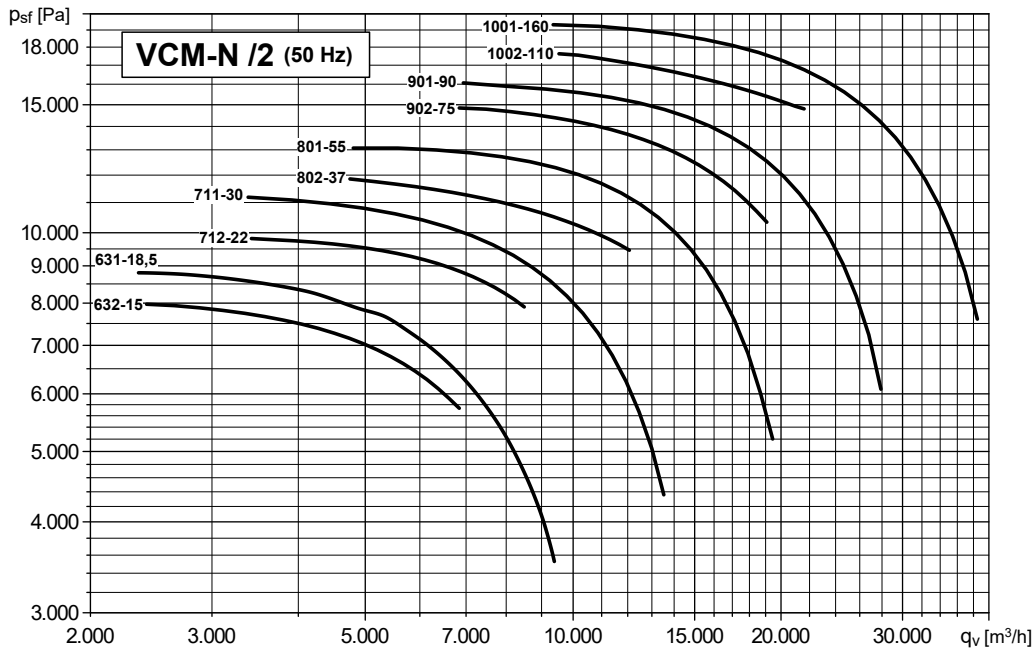

CURVAS CARACTERÍSTICAS (a la descarga) / PERFORMANCE CURVES (at outlet)

- Ventiladores ensayados con la aspiración y la descarga entubadas.
- Caudal en m³/h.
- **Psf: Presión estática en Pa.**
- Modelo - Potencia motor en kW.
- Ejemplo: 712 - 4
 Modelo - kW

- Fan ducted on both inlet and outlet sides.
- Air volume in m³/h.
- **Psf: Static pressure in Pa.**
- Model - Motor power in kW.
- Example: 712 - 4
 Model - kW

4 polos - Modelos desde 711 hasta 1001
 4 pole - Models from 711 to 1001

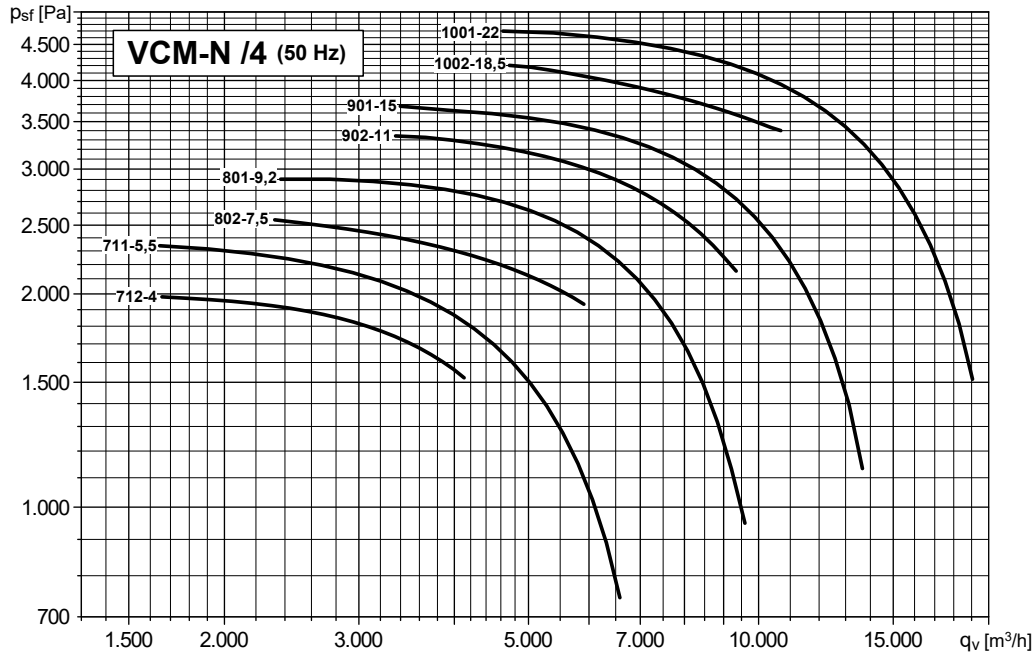

Datos ERP / ERP data

Modelo Model	PM	MC	EC	VSD	SR	η [%]	N	[kW]	[m ³ /h]	[Pa]	[RPM]
VCM 352 N4A	0,8	B	total	No	1	65,1	76,9	0,743	1.046	1665	2830
VCM 351 N4A	1,1	B	total	No	1	65,3	76,6	0,845	1.087	1827	2850
VCM 402 N4A	1,5	B	total	No	1	68,3	77,6	1,282	1.509	2088	2840
VCM 401 N4A	2,2	B	total	No	1	68,7	77,2	1,575	1.635	2384	2890
VCM 452 N4A	3,0	B	total	No	1	71,4	78,3	2,218	2.043	2792	2900
VCM 451 N4A	4,0	B	total	No	1	72,1	78,1	2,680	2.219	3134	2910
VCM 502 N4A	4,0	B	total	No	1	73,2	77,7	3,807	2.795	3593	2910
VCM 501 N4A	5,5	B	total	No	1	73,4	76,9	4,596	3.034	4000	2890
VCM 562 N4A	7,5	B	total	No	1	74,4	75,9	7,163	4.183	4587	2890
VCM 561 N4A	11,0	B	total	No	1	74,4	75,5	7,966	4.230	5045	2935
VCM 632 N4A	15,0	B	total	No	1	76,9	76,7	12,359	5.922	5775	2935
VCM 631 N4A	18,5	B	total	No	1	77,3	77,0	13,973	6.014	6463	2935
VCM 712 N4A	22,0	B	total	No	1	77,7	76,9	22,493	8.454	7443	2940
VCM 711 N4A	30,0	B	total	No	1	78,5	77,5	25,978	8.627	8508	2960
VCM 802 N4A	37,0	B	total	No	1	78,5	77,1	39,045	11.971	9219	2960
VCM 801 N4A	55,0	B	total	No	1	80,5	78,9	46,446	12.376	10876	2960
VCM 902 N4A	75,0	B	total	No	1	79,5	77,4	71,045	17.509	11618	2960
VCM 901 N4A	90,0	B	total	No	1	80,8	78,6	84,372	17.870	13742	2960
VCM 1002 N4A	110,0	B	total	No	1	80,7	78,1	114,309	21.665	15331	2970
VCM 1001 N4A	160,0	B	total	No	1	82,1	79,3	139,461	24.508	16828	2970
VCM 712 N4A	4,0	B	total	No	1	73,9	79,8	2,793	4.148	1792	1425
VCM 711 N4A	5,5	B	total	No	1	75,7	80,8	3,248	4.263	2077	1440
VCM 802 N4A	7,5	B	total	No	1	75,9	79,2	4,869	5.915	2251	1450
VCM 801 N4A	9,2	B	total	No	1	76,8	79,3	5,869	6.115	2655	1460
VCM 902 N4A	11,0	B	total	No	1	76,5	77,0	8,872	8.637	2827	1460
VCM 901 N4A	15,0	B	total	No	1	78,0	78,0	10,503	8.815	3344	1450
VCM 1002 N4A	18,5	B	total	No	1	78,0	77,7	14,202	10.687	3731	1470
VCM 1001 N4A	22,0	B	total	No	1	79,3	78,7	17,349	12.089	4095	1470

PM Potencia del motor / *Motor power*

MC Categoría de medición / *Measurement category*

EC Categoría de eficiencia / *Efficiency category*

VSD Mando de regulación de velocidad: debe suministrarse con el ventilador / *Speed control: supplied with the fan*

SR Relación específica / *Specific ratio*

η [%] Eficiencia / *Total efficiency*

N Grado de eficiencia / *Efficiency*

[kW] Potencia absorbida / *Absorbed power*

[m³/h] Caudal / *Airflow*

[Pa] Presión total / *Total pressure*

[RPM] Velocidad / *Speed*

RODETE ÁLABES CURVADOS HACIA ATRÁS - ACOPLAMIENTO DIRECTO BACKWARD CURVED IMPELLER - DIRECT DRIVE



DIMENSIONES (mm) / DIMENSIONS (mm)

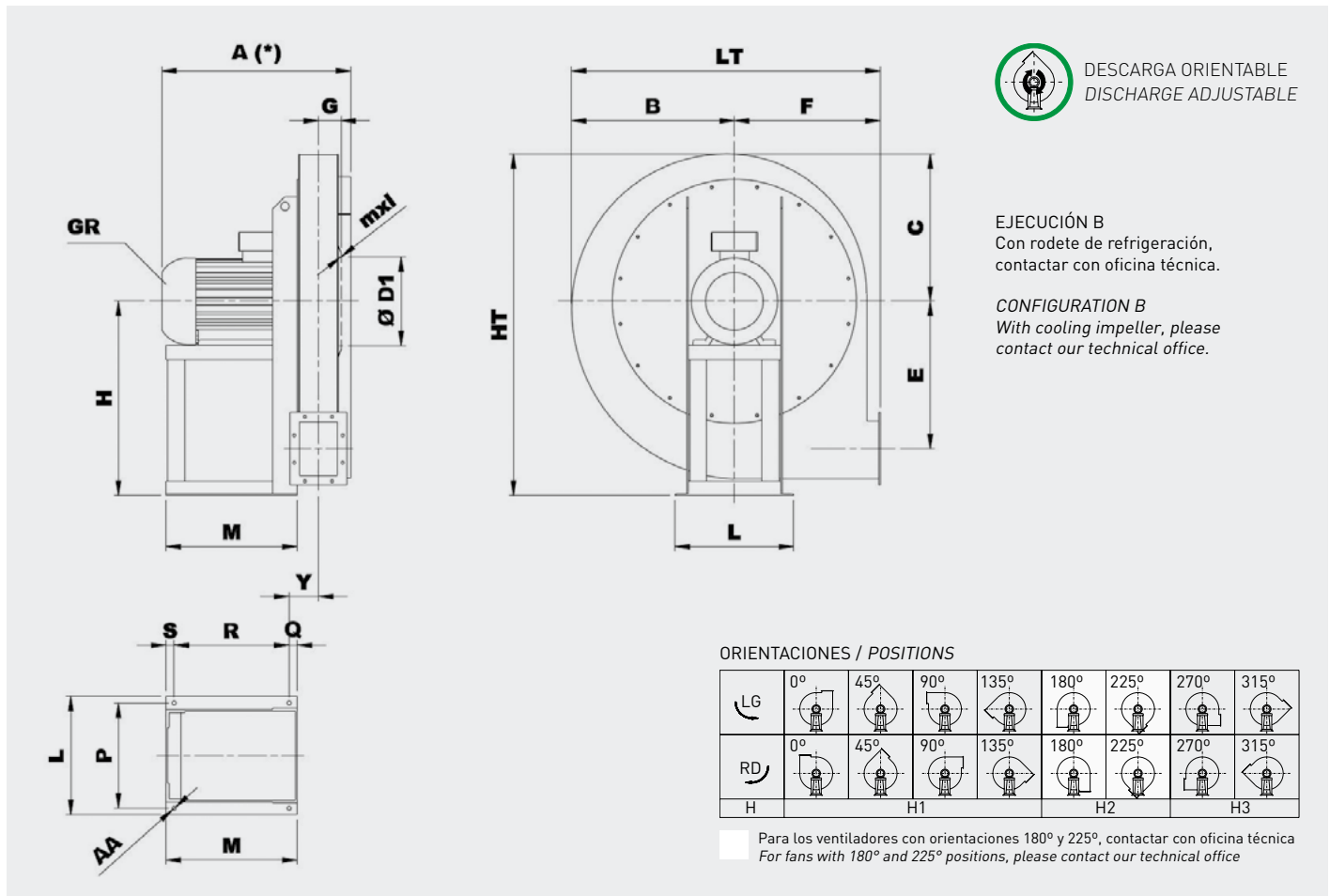

Tipo Type	Ventilador Fan														Base Base							
Ventilador Fan	Motor GR Motor GR	A*	B	C	Ø D1	E	F	G	H			HT	mxl	Y	LT	L	P	M	Q	R	S	AA
									H1	H2	H3											
VCM 351/2 N4A	80B2	400	285	260	219	220	250	61	355	250	355	615	M6X20	101	535	225	203	225	45	166	14	10
VCM 352/2 N4A	80A2	400	285	260	219	220	250	61	355	250	355	615	M6X20	101	535	225	203	225	45	166	14	10
VCM 401/2 N4A	90L2	455	310	280	241	242	280	67	375	280	375	655	M6X20	121	590	260	234	260	60	183	17	10
VCM 402/2 N4A	90S2	430	310	280	241	242	280	67	375	280	375	655	M6X20	121	590	260	234	260	60	183	17	10
VCM 451/2 N4A	112M2	555	345	315	265	269	300	76	400	300	400	715	M6X20	93	645	324	289	310	23	264	23	12
VCM 452/2 N4A	100LA2	515	345	315	265	269	300	76	400	300	400	715	M6X20	93	645	324	289	295	23	249	23	12
VCM 501/2 N4A	132SA2	585	380	350	292	302	335	83	450	335	450	800	M8X25	101	715	372	337	360	23	314	23	12
VCM 502/2 N4A	112M2	565	380	350	292	302	335	83	450	335	450	800	M8X25	101	715	372	337	360	23	314	23	12
VCM 561/2 N4A	160MR2	750	430	390	332	343	375	92	500	375	500	890	M8X25	115	805	440	395	470	28	414	28	14
VCM 562/2 N4A	132SB2	630	430	390	332	343	375	92	500	375	500	890	M8X25	110	805	372	337	360	23	314	23	12
VCM 631/2 N4A	160L2	770	485	440	366	381	425	104	560	425	560	1000	M8X25	126	910	440	395	470	28	414	28	14
VCM 632/2 N4A	160M2	770	485	440	366	381	425	104	560	425	560	1000	M8X25	126	910	440	395	470	28	414	28	14
VCM 711/2 N4A	200L2	955	540	490	405	426	475	115	630	475	630	1120	M8X25	189	1015	568	506	552	80	433	39	19
VCM 711/4 N4A	132SA4	670	540	490	405	426	475	115	630	475	630	1120	M8X25	132	1015	372	337	360	23	314	23	12
VCM 712/2 N4A	180M2	845	540	490	405	426	475	115	630	475	630	1120	M8X25	142	1015	488	434	540	33	474	33	17
VCM 712/4 N4A	112M4	650	540	490	405	426	475	115	630	475	630	1120	M8X25	132	1015	324	289	310	23	264	23	12
VCM 801/2 N4A	250M2	1090	610	550	448	481	530	127	710	530	710	1260	M8X25	211	1140	676	604	675	90	541	44	19
VCM 801/4 N4A	132MB4	760	610	550	448	481	530	127	710	530	710	1260	M8X25	144	1140	372	337	360	23	314	23	12
VCM 802/2 N4A	200L2	1000	610	550	448	481	530	127	710	530	710	1260	M8X25	201	1140	568	506	575	80	456	39	19
VCM 802/4 N4A	132MA4	760	610	550	448	481	530	127	710	530	710	1260	M8X25	144	1140	372	337	360	23	314	23	12
VCM 901/2 N4A	280M2	1210	685	620	497	542	600	144	800	600	800	1420	M8X25	235	1285	770	690	690	100	540	50	21
VCM 901/4 N4A	160L4	805	685	620	497	542	600	144	800	600	800	1420	M8X25	163	1285	440	395	470	28	414	28	14
VCM 902/2 N4A	280S2	1210	685	620	497	542	600	144	800	600	800	1420	M8X25	235	1285	770	690	690	100	540	50	21
VCM 902/4 N4A	160M4	805	685	620	497	542	600	144	900	600	800	1420	M8X25	163	1285	440	395	470	28	414	28	14
VCM 1001/2 N4A	315MG2	1300	760	690	551	607	670	160	900	670	900	1590	M8X25	262	1430	850	760	800	110	635	55	21
VCM 1001/4 N4A	180L4	1000	760	690	551	607	670	160	900	670	900	1590	M8X25	185	1430	488	434	540	33	474	33	17
VCM 1002/2 N4A	315S2	1300	760	690	551	607	670	160	900	670	900	1590	M8X25	262	1430	850	760	800	110	635	55	21
VCM 1002/4 N4A	180M4	1000	760	690	551	607	670	160	900	670	900	1590	M8X25	185	1430	488	434	540	33	474	33	17

* Según tamaño motor / Depending on motor size

RODETE ÁLABES CURVADOS HACIA ATRÁS - ACOPLAMIENTO DIRECTO BACKWARD CURVED IMPELLER - DIRECT DRIVE



DIMENSIONES (mm) / DIMENSIONS (mm)

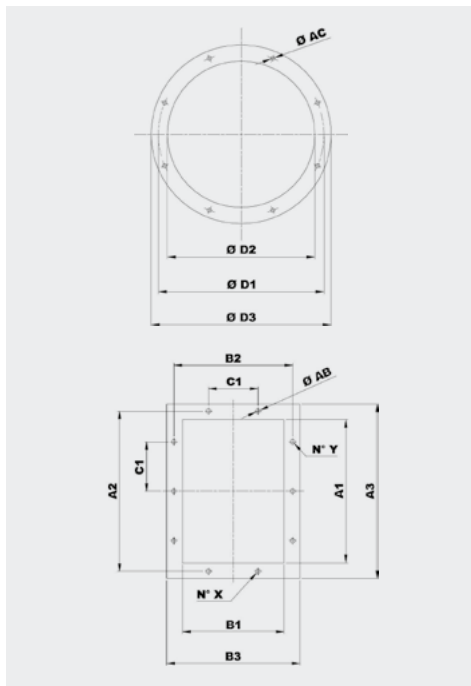

Modelo Model	Brida aspiración Inlet flange					
	Tipo brida Bride type	Ø D1	Ø D2	Ø D3	Ø AC	Agujeros Holes
351	180	219	184	254	8	8
401	200	241	204	274	8	8
451	224	265	228	298	8	8
501	250	292	254	324	10	8
561	280	332	285	365	10	8
631	315	366	320	400	10	8
711	355	405	360	440	10	8
801	400	448	405	485	10	12
901	450	497	455	535	10	12
1001	500	551	505	585	10	12

Modelo Model	Brida descarga Discharge flange										
	Tipo brida Bride type	A1	B1	A2	B2	A3	B3	C1	Ø AB	N° X	N° Y
351	140x100	146	105	182	139	216	175	112	12	1+1	2+2
401	160x112	164	117	200	151	234	187	112	12	1+1	2+2
451	180x125	183	131	219	165	253	201	112	12	1+1	2+2
501	200x140	205	146	241	182	275	216	112	12	2+2	2+2
561	224x160	229	164	265	200	299	234	112	12	2+2	2+2
631	250x180	256	183	292	219	326	253	112	12	2+2	3+3
711	280x200	288	205	332	249	368	285	125	12	2+2	3+3
801	315x224	322	229	366	273	402	309	125	12	2+2	3+3
901	355x250	361	256	405	300	441	336	125	12	2+2	3+3
1001	400x280	404	288	448	332	484	368	125	12	3+3	4+4

AMORTIGUADORES / SILENT BLOCKS

Amortiguadores recomendados / Suggested silent blocks	
Ventilador / Fan	Ejecución 4 / Arrangement 4
351/2	4 x AM20 - 20 x 20
401/2	4 x AM25 - 25 x 20
451/2	4 x AM25 - 25 x 20
501/2	4 x AM30 - 30 x 30
561/2	4 x AM40 - 40 x 30
631/2	4 x AM50 - 50 x 40
711/2	4 x AM75 - 75 x 50
801/2	4 x AM75 - 75 x 50
901/2	4 x AZ39 - 140 x 39
1001/2	4 x AZ39 - 140 x 39

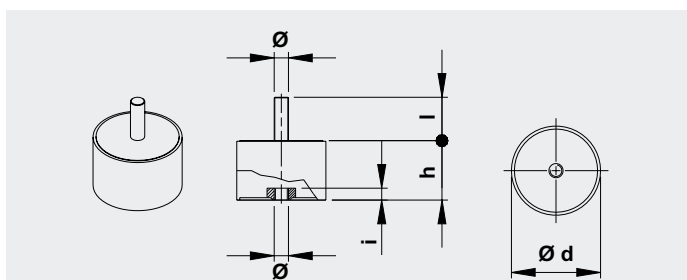

Tipo Type	Carga para 4 soportes Load for 4 supports (kg)	d	h	Ø	l	Peso Weight (kg)
AM20	11÷40	20	20	M6	15	0,02
AM25	41÷80	25	20	M6	18	0,03
AM30	81÷140	30	30	M8	20	0,05
AM40	141÷224	40	30	M8	23	0,10
AM50	225÷315	50	40	M10	28	0,20
AM75	316÷630	75	50	M12	37	0,50

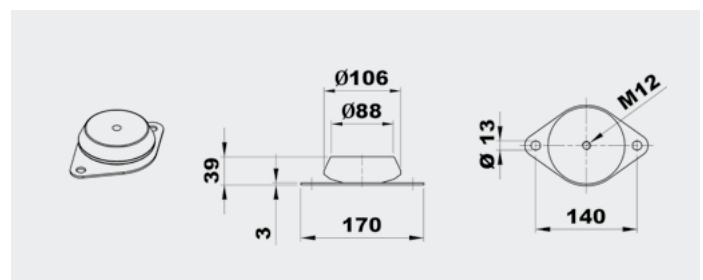

Tipo Type	Carga para 4 soportes Load for 4 supports (kg)	Peso Weight (kg)
AZ 39	631÷1250	0,7

ACCESORIOS / ACCESSORIES

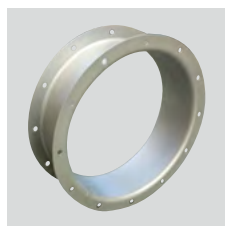

CA (CFH1) - CFH2 - CFH3
 Contrabrida -
 Brida plana circular.
*Counter-flange -
 Circular flange.*

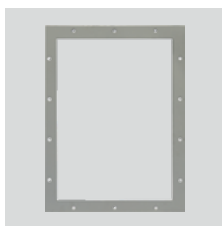

CP
 Brida plana
 rectangular.
Rectangular Flange.

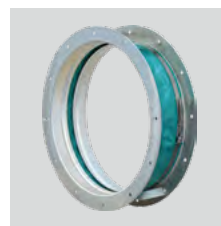

GA
 Junta flexible
 aspiración.
*Inlet flexible
 connector.*



GP
 Junta flexible
 descarga.
*Outlet flexible
 connector.*



DP
 Regulador de caudal
 de aspiración.
*Inlet damper
 governor.*



SAD
 Compuerta de
 regulación de caudal
 de descarga.
*Air reducing damper
 at outlet.*



SF
 Vávula mariposa.
Throttle valve.



DF
 Filtro en la
 aspiración.
Air filter at inlet.

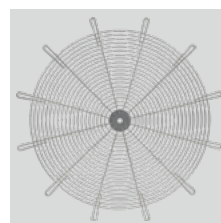

RC
 Rejilla de protección
 para la aspiración.
Protection net.



AM/AZ
 Soportes
 antivibratorios.
Silent blocks.



SCSO
 Silenciador
 cilíndrico.
*Cylindrical sound
 attenuator.*



SCCO
 Silenciador cilíndrico
 con bulbo.
*Cylindrical sound
 attenuator with
 internal pot.*

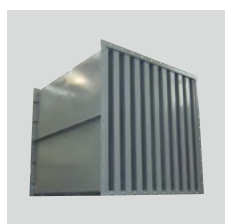

SASS
 Silenciador
 rectangular.
*Baffle type sound
 attenuator.*

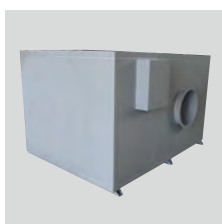

CI
 Cabina de
 insonorización.
Noise enclosure.

Ver información completa en "Accesorios de montaje".
 For more information see "Mounting accessories".

VCM



Rodete de álabes hacia atrás
 Backward curved impeller

Ventilador centrífugo con accionamiento por poleas y correas y simple aspiración. Fabricados en chapa de acero protegida contra la corrosión mediante tratamiento por cataforesis + pintura poliuretana. Temperaturas del aire a transportar -20°C/+100°C en continuo.

Sistemas de montaje

- SISTEMA 1: eje libre, para acoplamiento mediante poleas y correas.
- SISTEMA 9: incluye motor, poleas, correas y protector de correas. Motor montado en el lateral del pie soporte rodamientos.
- SISTEMA 12: incluye motor, poleas, correas y protector de correas. Motor montado sobre la bancada general.

Motores

De 2, 4 o 6 polos, de alta eficiencia IE 3* (las r.p.m. de cada motor se adaptarán al cálculo de cada transmisión), tensión de alimentación trifásica 230/400V 50Hz tamaño motor 112 y 400/690V 50Hz para motores de mayor dimensión. Protección IP55, Clase F.

* A partir de 0,75 kW el motor puede ser de eficiencia IE 2 controlado por convertidor de frecuencia.

Bajo pedido

- Fabricación en diferentes materiales constructivos.
- Motores de 2 velocidades.
- Versiones de 60 Hz.
- Pintura en diferentes RAL.
- Versión para alta temperatura: hasta 300°C (versiones B: con rodete de refrigeración).
- Trampilla de inspección, purga de drenaje, distintos tipos de estanqueidad a nivel de voluta y de paso de eje.
- Ventiladores estancos.
- Calorifugado.

Versiones ATEX

Bajo pedido, versiones antiexplosivas según la Directiva ATEX para modelos trifásicos:

Para trabajar a temperaturas de -20°C a +60°C, presión ambiente (absoluta) de 0,8 bar hasta 1,1 bar, según EN 14986.

- Gas:
 - ⊗ 2G IIB T2-T3
 - ⊗ 2G IIB+H2 T2-T3
 - ⊗ 3G IIB T2-T3
 - ⊗ 3G IIB+H2 T2-T3
- Polvo no conductivo:
 - ⊗ 2D IIIB T195°C-T295°C
 - ⊗ 3D IIIB T195°C-T295°C
- Polvo conductivo (con motor IP65 IIIC):
 - ⊗ 2D IIIC T195°C-T295°C
 - ⊗ 3D IIIC T195°C-T295°C

CUADRO DE APLICACIONES
 TABLE OF APPLICATIONS

Aire a transportar Air Type	Cantidad de polvo Dust quantity (mg/m ³)
Polvoriento (ambiente industrial) Medium dust (industrial environment)	<500

Single inlet centrifugal fans, for belt drive. Manufactured from steel sheet protected with cataforesis primer + polyurethane paint finish. Designed to continuously circulate air from -20°C up to 100°C.

Assembly systems

- ARRANGEMENT 1: Free shaft, for pulley or belt-drive.
- ARRANGEMENT 9: Includes motor, pulleys, belts and belt guard. Motor fitted on the side of the bearing mounting bracket.
- ARRANGEMENT 12: Includes motor, pulleys, belts and belt guard. Motor fitted on the base frame.

Motors

2, 4 or 6 pole, IE 3* high efficiency (the rpm of each motor will be adapted according to the calculation for each drive), three-phase 230/400V 50Hz up to motor size 112 and 400/690V 50Hz for higher motors. IP55, Class F protection.

* From 0,75kW, motor can be IE 2 and controlled by VSD.

On request

- Manufactured from different materials.
- 2-speed motors.
- 60 Hz versions.
- Painted in different RAL colour.
- High-temperature versions (up to 300°C) (B versions: with cooling impeller).
- Inspection door, draining, different seals on scroll and shaft access.
- Welded casing.
- Thermal insulation lagging.

ATEX versions

On request, explosion proof versions in accordance with ATEX directive for three phase models:

Ambient temperature -20°C to +60°C, ambient pressure (abs.) 0,8 bar to 1,1 bar according to EN 14986.

- Gas:
 - ⊗ 2G IIB T2-T3
 - ⊗ 2G IIB+H2 T2-T3,
 - ⊗ 3G IIB T2-T3
 - ⊗ 3G IIB+H2 T2-T3
- Non-conductive dust:
 - ⊗ 2D IIIB T195°C-T295°C
 - ⊗ 3D IIIB T195°C-T295°C
- Conductive dust (compulsory IP65 IIIC motor):
 - ⊗ 2D IIIC T195°C-T295°C
 - ⊗ 3D IIIC T195°C-T295°C

CARACTERÍSTICAS TÉCNICAS / TECHNICAL FEATURES

Es imprescindible comprobar que las características eléctricas (voltaje, intensidad, frecuencia, etc.) del motor que aparecen en la placa del mismo son compatibles con las de la instalación.

Please, check that electrical features (voltage, current, frequency, etc.) are suitable with your installation.

Modelo Model	Caudal máximo Maximum airflow (m ³ /h)	Potencia motor máxima Maximum motor power (kW)	Peso Weight (kg) ⁽¹⁾	Momento de inercia Moment of inertia (kg·m ²) ⁽²⁾
VCM 351 N1A	2.900	4,0	30	0,08
VCM 401 N1A	4.660	7,5	64	0,13
VCM 451 N1A	5.400	9,2	62	0,24
VCM 501 N1A	7.350	18,5	82	0,38
VCM 561 N1A	9.150	18,5	120	0,65
VCM 631 N1A	12.800	37,0	170	1,10
VCM 711 N1A	16.230	45,0	223	2,00
VCM 801 N1A	23.330	75,0	398	3,50
VCM 901 N1A	29.700	90,0	475	5,00
VCM 1001 N1A	36.290	160,0	685	9,50
VCM 1121 N1A	45.720	160,0	755	15,00
VCM 1251 N1A	64.150	200,0	1.120	24,00
VCM 1401 N1A	72.000	250,0	1.237	42,00
VCM 1601 N1A	95.180	315,0	1.622	72,00
VCM 1801 N1A	119.810	400,0	2.179	125,00
VCM 2001 N1A	144.000	500,0	2.870	225,00

¹ Para ejecución 1 y orientación LG270 o RD270 / For arrangement 1 and LG270 or RD270 position

² Momento de inercia del rodetes / Impeller's moment of inertia

SOPORTES SISTEMA 1 / SUPPORTS FOR ARRANGEMENT 1

Modelo Model	351	401	451-501	561	631	711	801
Soporte tipo Support type	ST 62 A24	ST 80 A28	ST 90 A38	ST 100 A42	ST 110 B48	ST 120 B48	ST 130 B55
Modelo Model	901	1001-1121	1251	1401	1601	1801-2001	
Soporte tipo Support type	ST 150 B65	ST 180 B80	ST 200 B90	SN 520 BL80	SN 522 BL90	SN 524 BL100	

Ver información adicional / See additional information

MOTORES SISTEMA 9 / MOTOR SIZE FOR ARRANGEMENT 9

Modelo Model	351	401-501	561-631	711-801	901-1001
Tamaño motor Motor size	≤ 100 L2	≤ 132 M2	≤ 160 L2-4	≤ 180 L2-4	≤ 200 M2-4-6

CURVAS CARACTERÍSTICAS (a la descarga) / PERFORMANCE CURVES (at outlet)

- Ptot: Presión total en Pa.
 - Ptot: Total pressure in Pa.

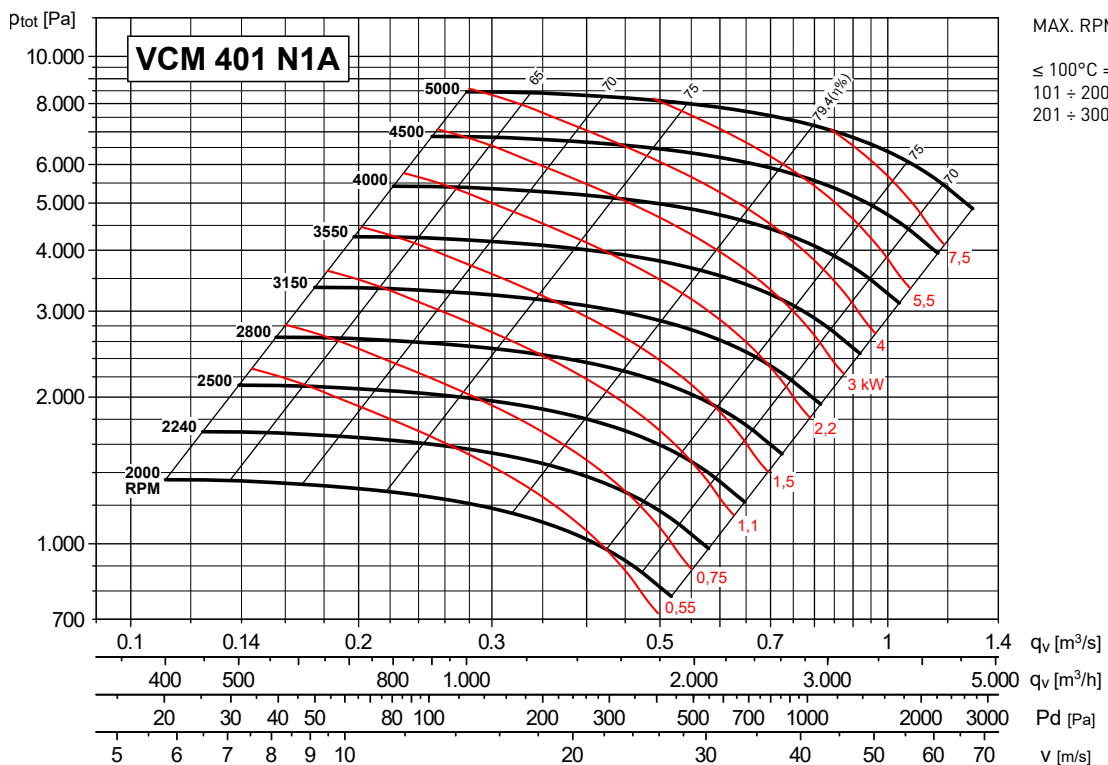
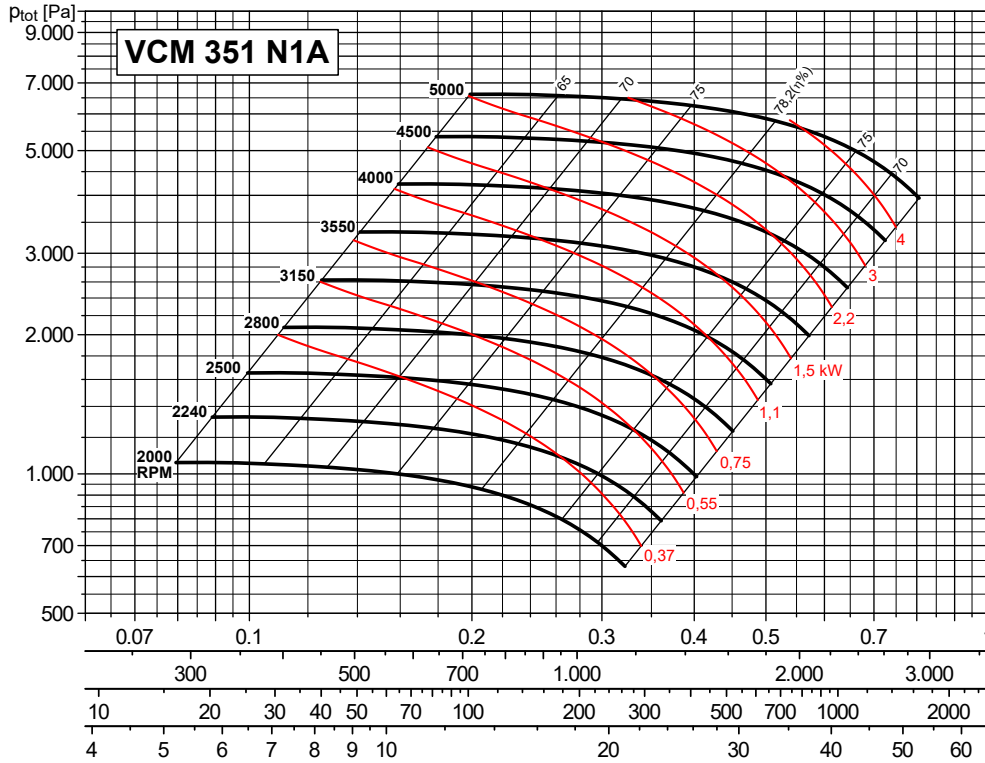

CURVAS CARACTERÍSTICAS (a la descarga) / PERFORMANCE CURVES (at outlet)

- Ptot: Presión total en Pa.
 - Ptot: Total pressure in Pa.

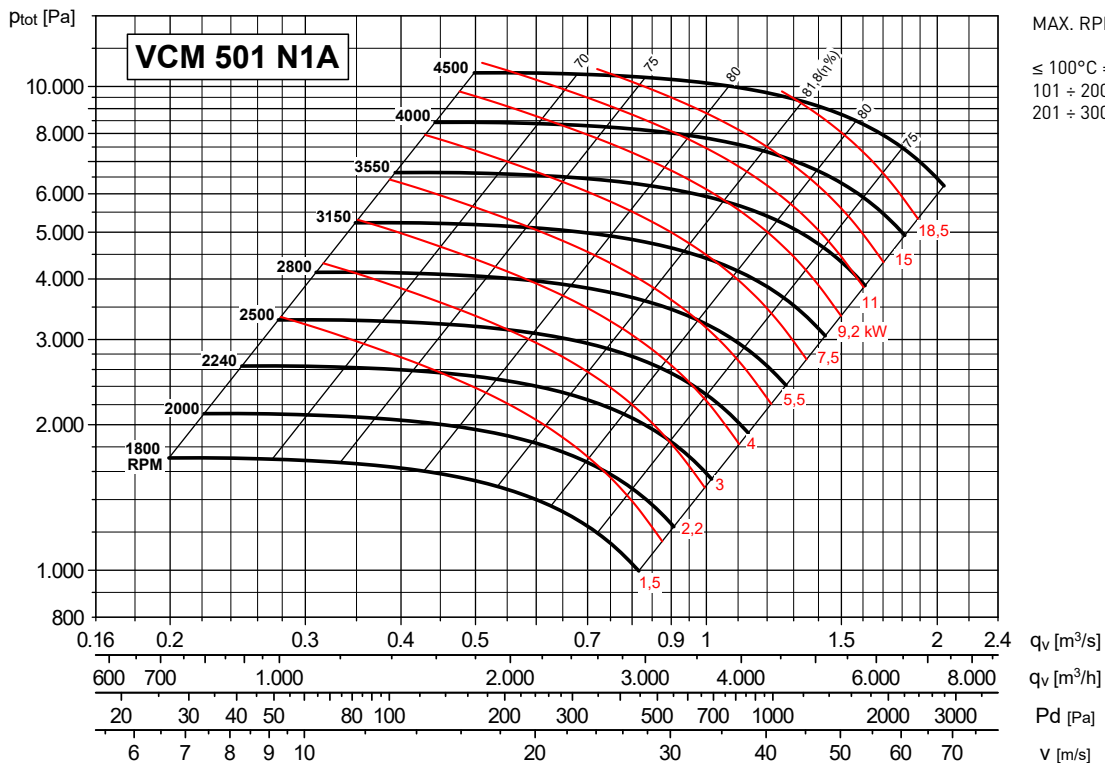
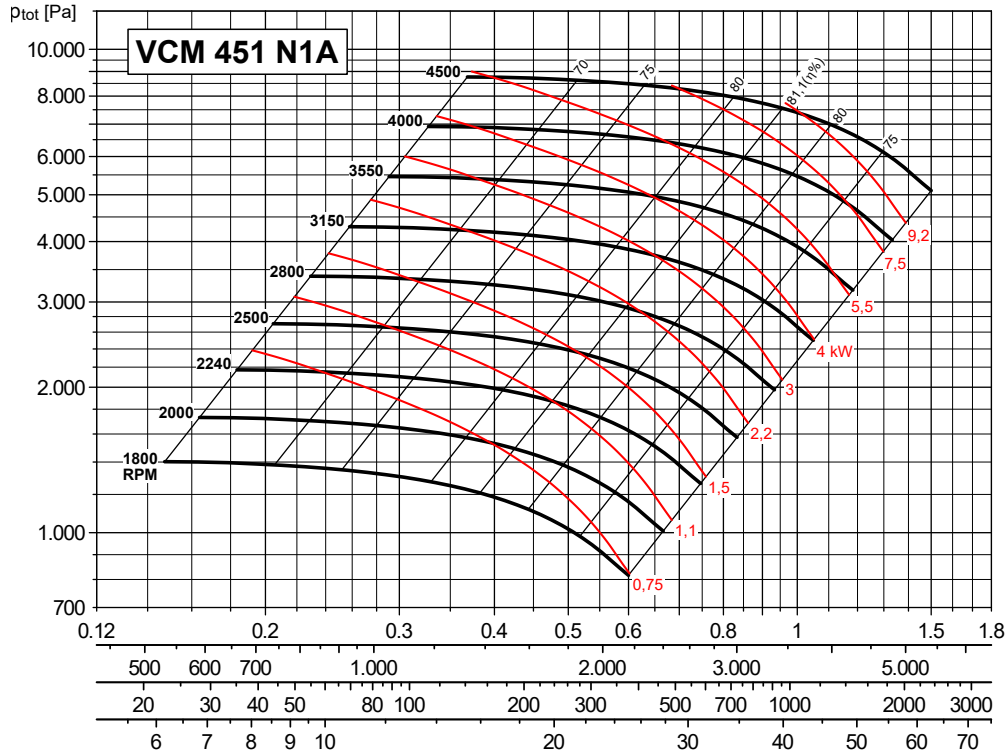

CURVAS CARACTERÍSTICAS (a la descarga) / PERFORMANCE CURVES (at outlet)

- Ptot: Presión total en Pa.
 - Ptot: Total pressure in Pa.

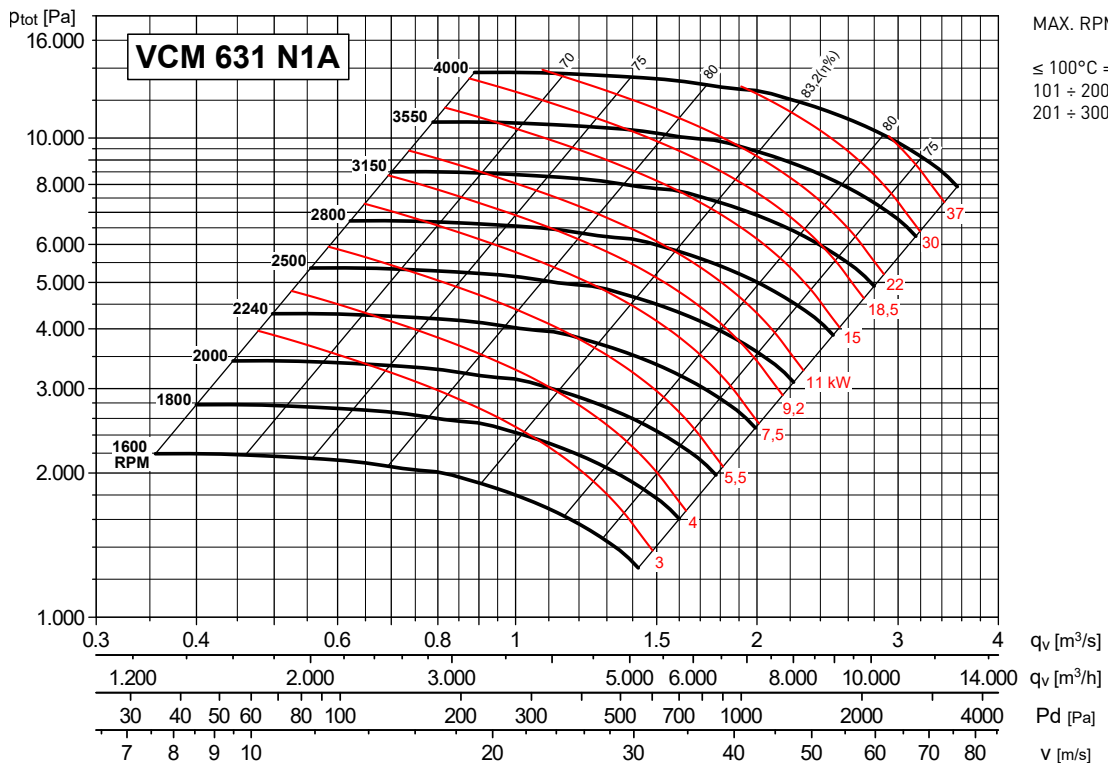
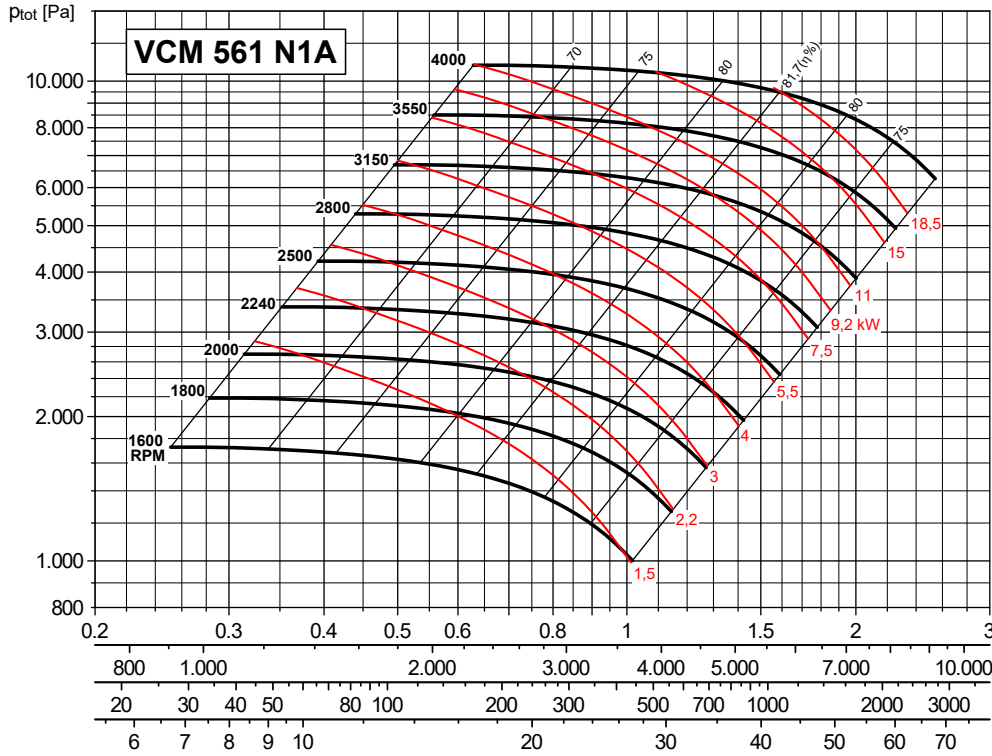

CURVAS CARACTERÍSTICAS (a la descarga) / PERFORMANCE CURVES (at outlet)

- P_{tot}: Presión total en Pa.
 - P_{tot}: Total pressure in Pa.

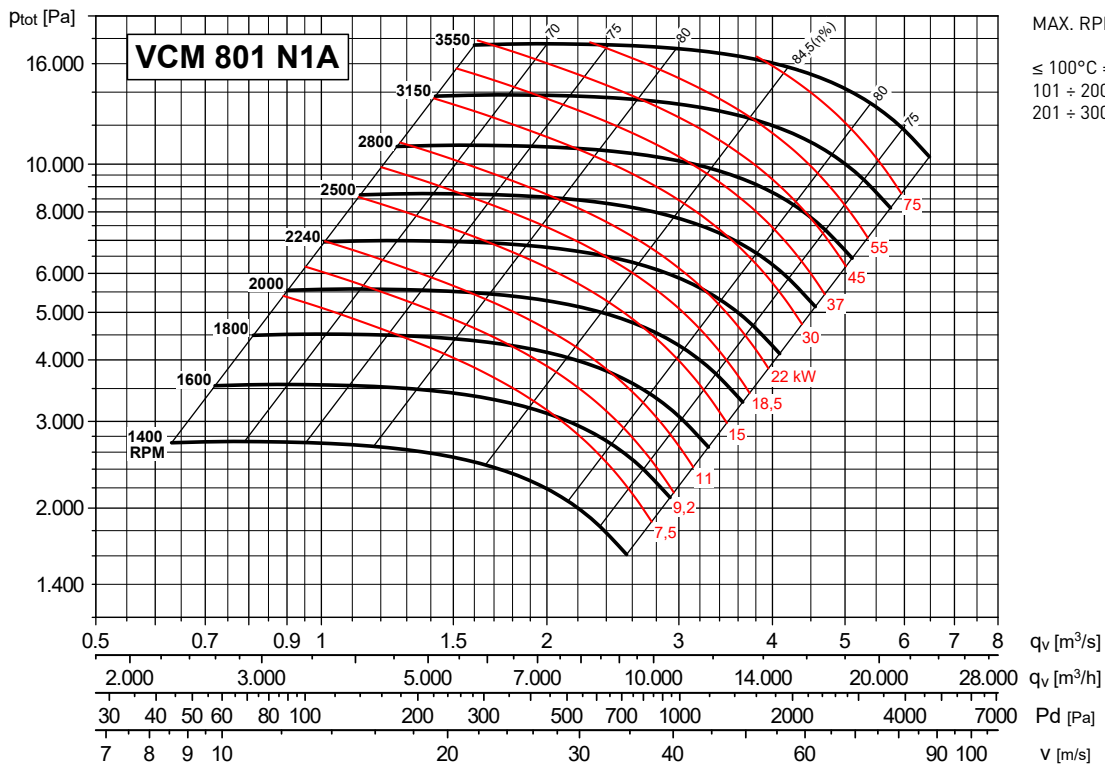
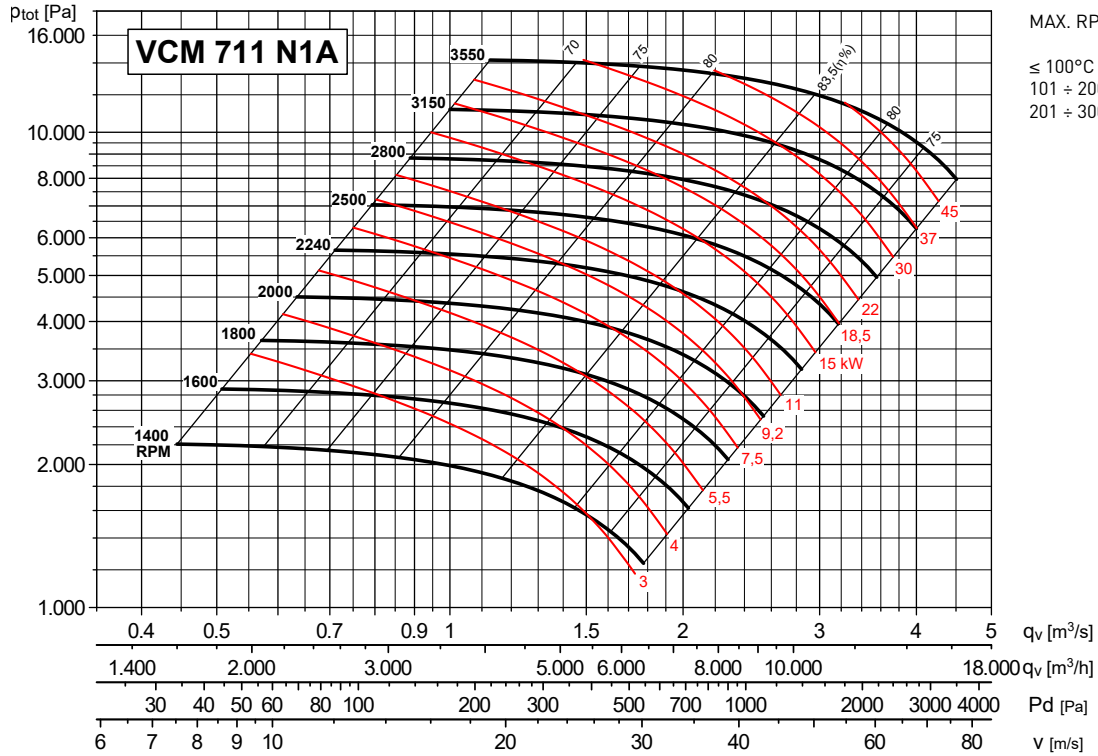

CURVAS CARACTERÍSTICAS (a la descarga) / PERFORMANCE CURVES (at outlet)

- Ptot: Presión total en Pa.
 - Ptot: Total pressure in Pa.

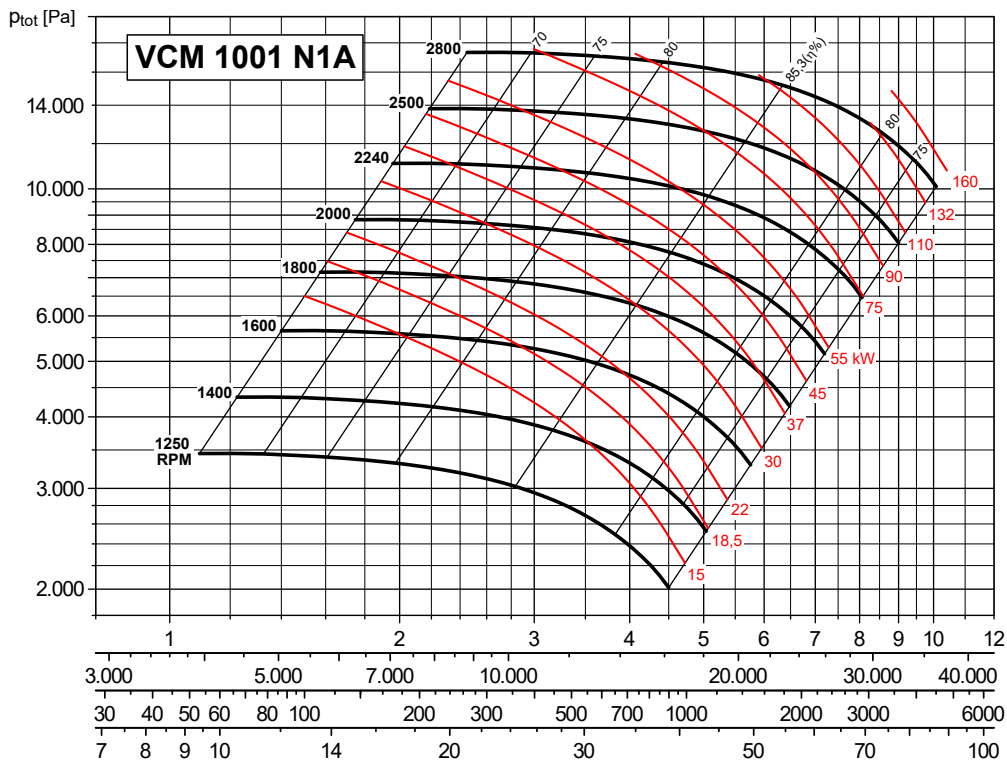
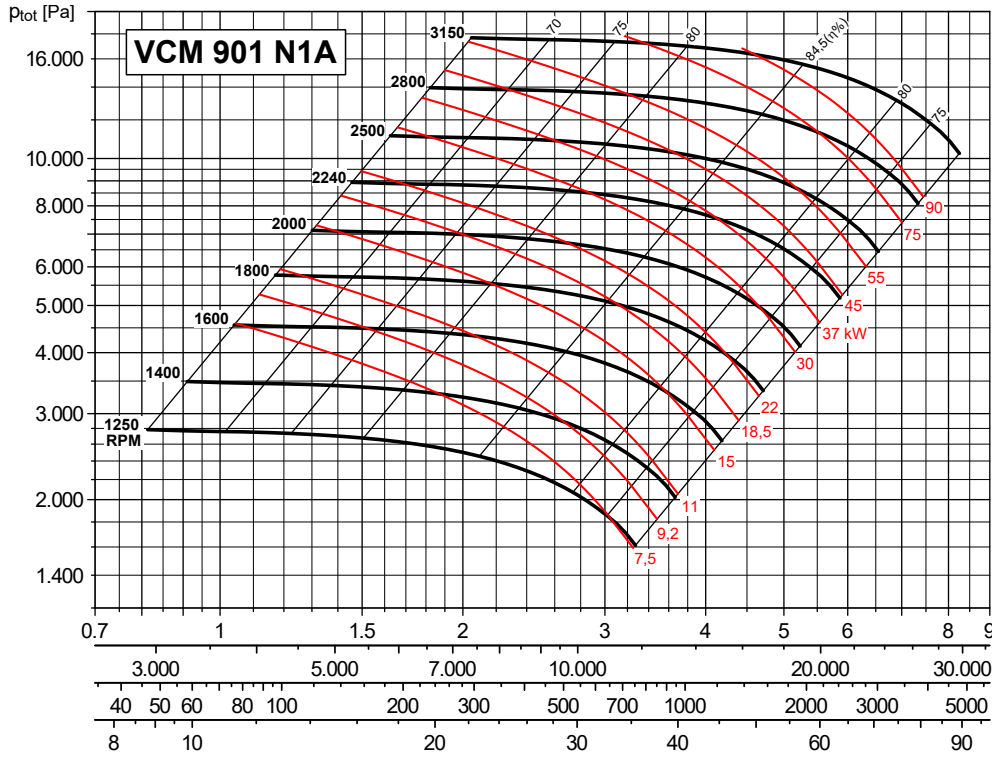

CURVAS CARACTERÍSTICAS (a la descarga) / PERFORMANCE CURVES (at outlet)

- Ptot: Presión total en Pa.
- Ptot: Total pressure in Pa.

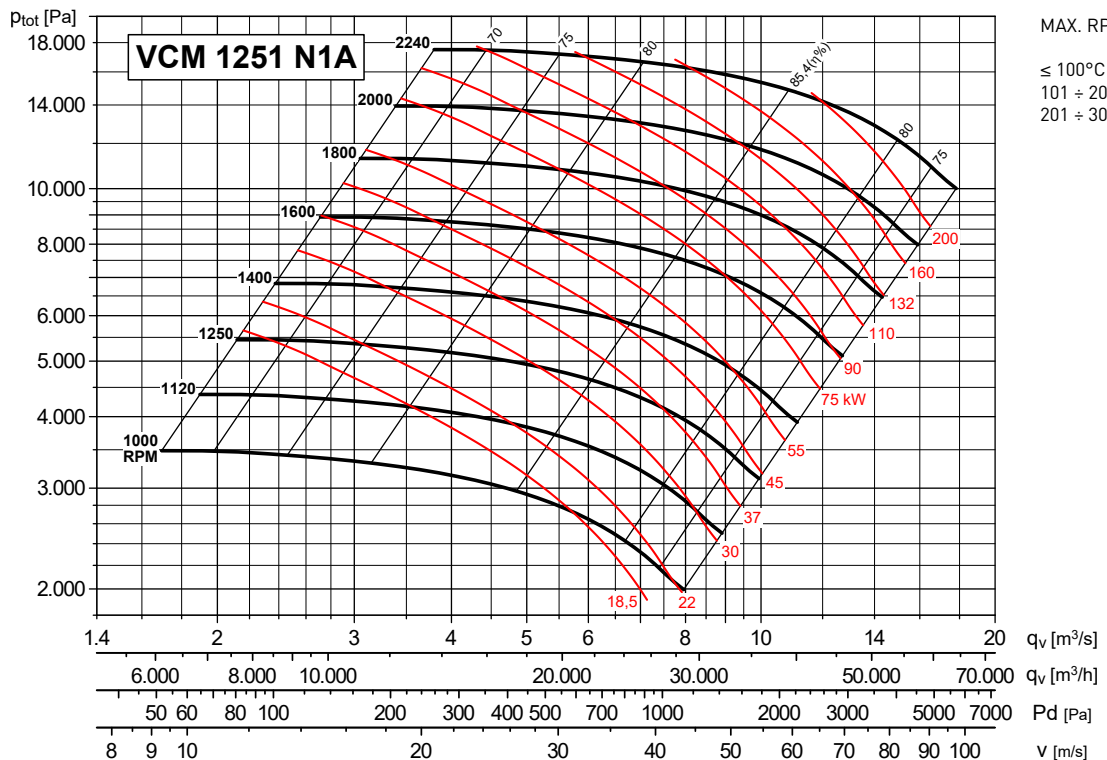
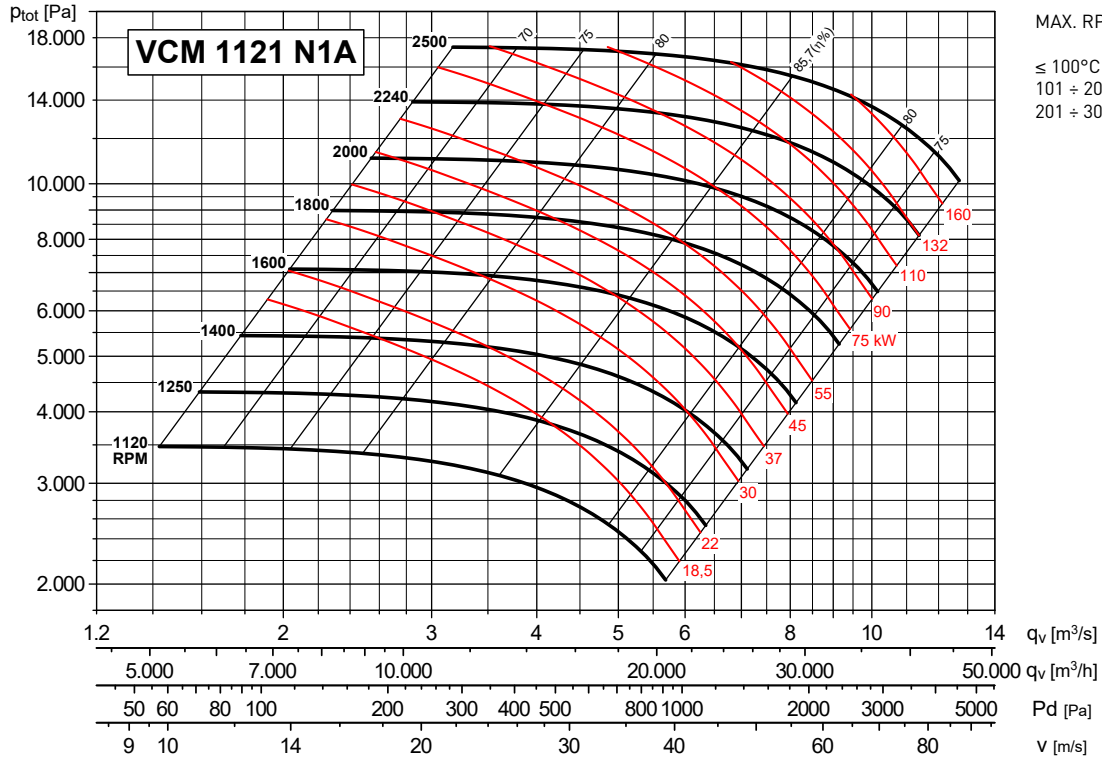

CURVAS CARACTERÍSTICAS (a la descarga) / PERFORMANCE CURVES (at outlet)

- Ptot: Presión total en Pa.
 - Ptot: Total pressure in Pa.

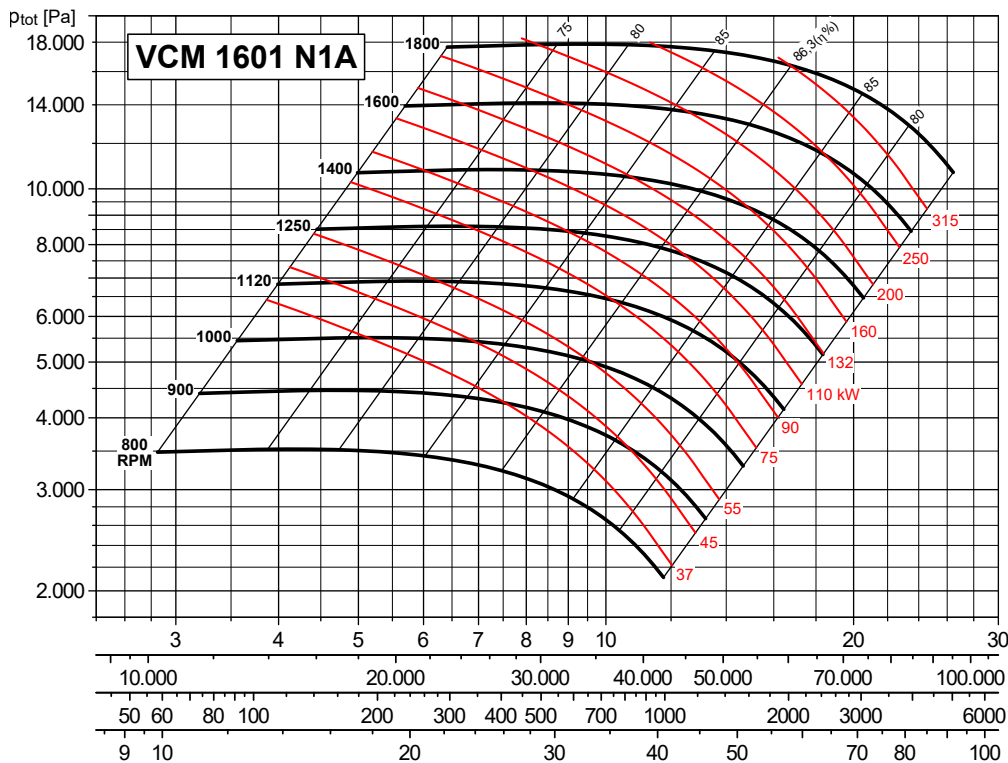
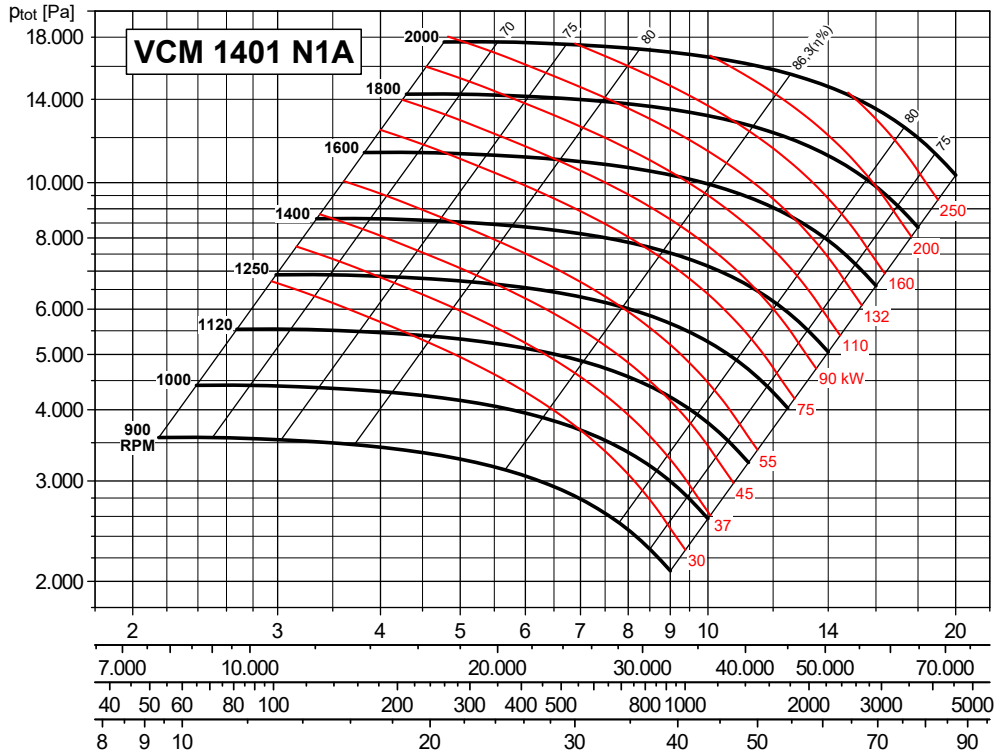

CURVAS CARACTERÍSTICAS (a la descarga) / PERFORMANCE CURVES (at outlet)

- P_{tot}: Presión total en Pa.
 - P_{tot}: Total pressure in Pa.

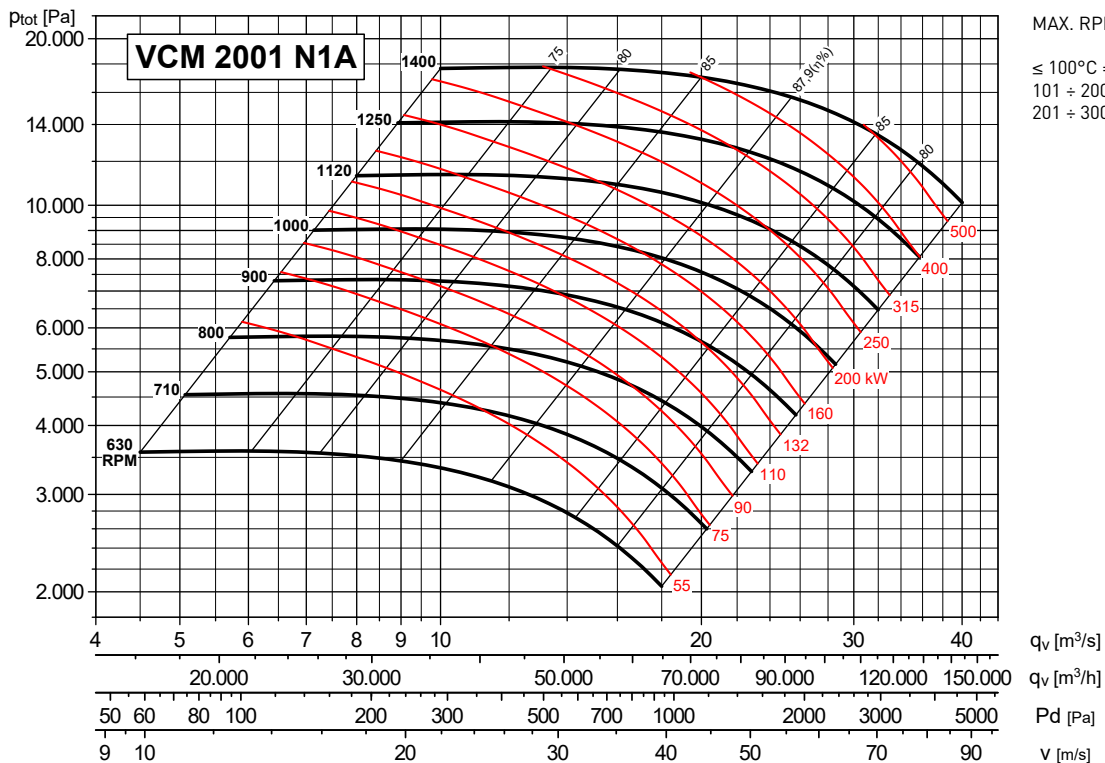
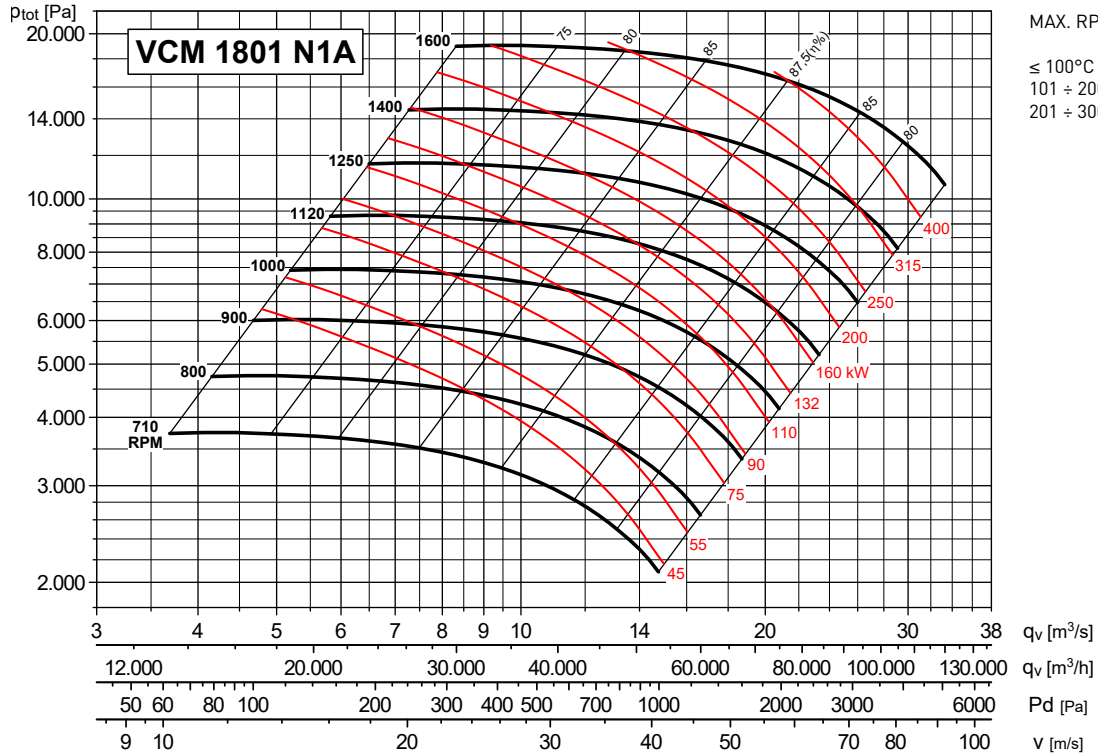

RODETE ÁLABES CURVADOS HACIA ATRÁS - ACOPLAMIENTO A TRANSMISIÓN BACKWARD CURVED IMPELLER - BELT DRIVE



DIMENSIONES (mm) (modelos desde 351 hasta 1001) / DIMENSIONS (mm) (models from 351 to 1001)

DESCARGA ORIENTABLE
DISCHARGE ADJUSTABLE

EJECUCIÓN B
Con rodete de refrigeración,
contactar con oficina técnica.

CONFIGURATION B
With cooling impeller, please
contact our technical office.

ORIENTACIONES / POSITIONS

LG	0°	45°	90°	135°	180°	225°	270°	315°
RD	0°	45°	90°	135°	180°	225°	270°	315°
H	H1			H2			H3	

Para estas orientaciones, contactar con oficina técnica
For these positions, please contact our technical office

Tipo ventilador Fan type	Ventilador Fan													Eje Shaft		Base Base							
	A	B	C	Ø D1	E	F	G	H			HT	mxl	Y	LT	L	Ø D	L2	P	M	Q	R	S	Ø AA
								H1	H2	H3													
VCM 351 N1A	540	285	260	219	220	250	61	355	250	355	615	M6X20	56	535	324	50	24	288	333	17	299	17	12
VCM 401 N1A	695	310	280	241	242	280	67	375	280	375	655	M6X20	61	590	400	60	28	355	463	23	417	23	14
VCM 451 N1A	742	345	315	265	269	300	76	400	300	400	715	M6X20	70	645	400	80	38	355	475	40	412	23	14
VCM 501 N1A	780	380	350	292	302	335	83	450	335	450	800	M8X25	78	715	400	80	38	355	485	45	417	23	14
VCM 561 N1A	905	430	390	332	343	375	92	500	375	500	890	M8X25	87	805	418	110	42	364	571	67	476	28	17
VCM 631 N1A	920	485	440	366	381	425	104	560	425	560	1000	M8X25	98	910	418	110	48	364	579	72	479	28	17
VCM 711 N1A	1010	540	490	405	426	475	115	530	475	630	1120	M8X25	109	1015	606	110	48	542	645	73	539	33	19
VCM 801 N1A	1060	610	550	448	481	530	127	600	530	710	1260	M8X25	121	1140	646	110	55	582	666	88	548	33	19
VCM 901 N1A	1150	685	620	497	542	600	144	670	600	800	1420	M8X25	135	1285	762	140	65	682	650	39	572	39	21
VCM 1001 N1A	1300	760	690	551	607	670	160	750	670	900	1590	M8X25	152	1430	862	170	80	782	710	39	632	39	21

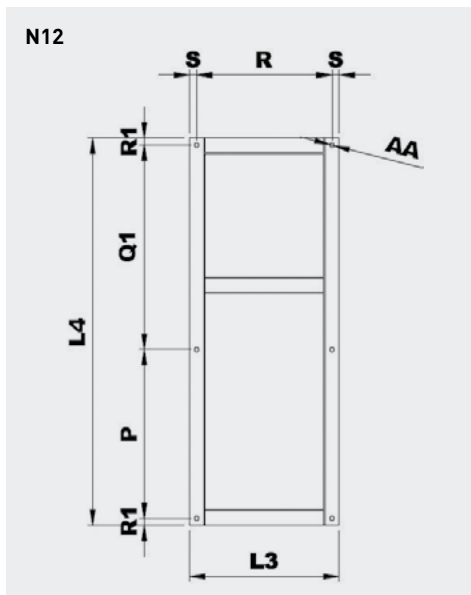

Modelo Model	Bancada ejecución 12 Base frame arrangement 12								Peso Weight (kg)
	P	L3	L4	Q1	R	R1	S	Ø AA	
351 N12A	288	333	850	526	299	18	17	12	23
401 N12A	355	463	1050	650	417	22,5	23	14	33
451 N12A	355	458	1060	660	412	22,5	23	14	35
501 N12A	355	463	1120	720	417	22,5	23	14	43
561 N12A	364	532	1180	762	476	27	28	17	55
631 N12A	364	535	1250	832	479	27	28	17	58
711 N12A	542	605	1500	894	539	32	33	19	72
801 N12A	582	614	1600	954	548	32	33	19	122
901 N12A	682	650	1800	1038	572	40	39	21	153
1001 N12A	782	710	2100	1238	632	40	39	21	230

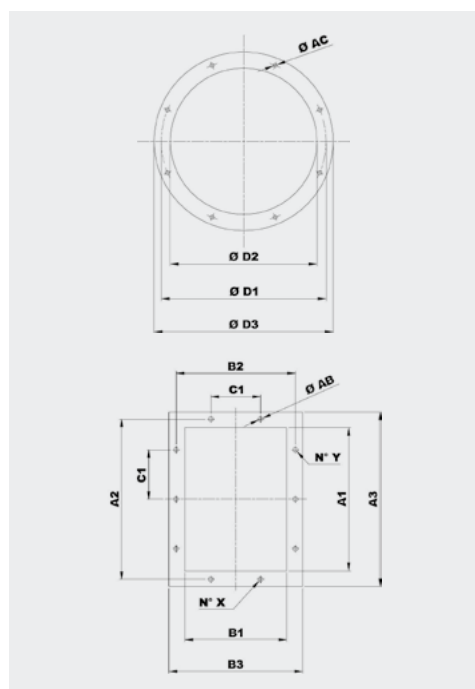

Modelo Model	Brida aspiración Inlet flange					
	Tipo brida Bride type	Ø D1	Ø D2	Ø D3	Ø AC	Agujeros Holes
351	180	219	184	254	8	8
401	200	241	204	274	8	8
451	224	265	228	298	8	8
501	250	292	254	324	10	8
561	280	332	285	365	10	8
631	315	366	320	400	10	8
711	355	405	360	440	10	8
801	400	448	405	485	10	12
901	450	497	455	535	10	12
1001	500	551	505	585	10	12

Modelo Model	Brida descarga Discharge flange										
	Tipo brida Bride type	A1	B1	A2	B2	A3	B3	C1	Ø AB	N°X	N°Y
351	140x100	146	105	182	139	216	175	112	12	1+1	2+2
401	160x112	164	117	200	151	234	187	112	12	1+1	2+2
451	180x125	183	131	219	165	253	201	112	12	1+1	2+2
501	200x140	205	146	241	182	275	216	112	12	2+2	2+2
561	224x160	229	164	265	200	299	234	112	12	2+2	2+2
631	250x180	256	183	292	219	326	253	112	12	2+2	3+3
711	280x200	288	205	332	249	368	285	125	12	2+2	3+3
801	315x224	322	229	366	273	402	309	125	12	2+2	3+3
901	355x250	361	256	405	300	441	336	125	12	2+2	3+3
1001	400x280	404	288	448	332	484	368	125	12	3+3	4+4

RODETE ÁLABES CURVADOS HACIA ATRÁS - ACOPLAMIENTO A TRANSMISIÓN BACKWARD CURVED IMPELLER - BELT DRIVE



DIMENSIONES (mm) (modelos desde 1121 hasta 2001) / DIMENSIONS (mm) (models from 1121 to 2001)

DESCARGA NO ORIENTABLE
DISCHARGE NON ADJUSTABLE

EJECUCIÓN B
Con rodetes de refrigeración,
contactar con oficina técnica.

CONFIGURATION B
With cooling impeller, please
contact our technical office.

ORIENTACIONES / POSITIONS

	0°	45°	90°	135°	180°	225°	270°	315°
	H	H1	H2	H3	H4	H5		

Para estas orientaciones, contactar con oficina técnica
For these positions, please contact our technical office

Tipo ventilador Fan type	Ventilador Fan															Eje Shaft		Base Base											
	A	B	C	ØD1	E	F	G	H					HT	LT	ØD	L2	L	L1	M	N	O	P2	R	S	T	U	V	Y	Ø AA
VCM 1121 N1A	1338	850	770	629	684	750	241	850	850	750	1000	1000	1770	1600	80	170	1268	1348	710	322	80	589	600	55	422	35	1112	216	24
VCM 1251 N1A	1455	955	865	698	772	850	271	950	950	850	1120	1120	1985	1805	80	170	1400	1480	800	361	80	655	710	45	451	35	1241	226	24
VCM 1401 N1A	1629	1070	970	775	864	950	302	1060	1060	950	1250	1250	2220	2020	80	170	1560	1640	935	404	80	725	780	55	549	35	1419	302	24
VCM 1601 N1A	1868	1254	1082	861	965	1060	342	1200	1120	1060	1400	1400	2482	2314	90	170	1750	1850	1102	453	80	820	917	65	628	45	1655	327	28
VCM 1801 N1A	1972	1406	1217	958	1090	1180	379	1330	1250	1180	1550	1400	2767	2586	100	210	1950	2070	1102	507	120	915	917	65	692	55	1729	374	28
VCM 2001 N1A	2049	1558	1353	1067	1215	1320	425	1500	1400	1320	1800	1600	3153	2878	100	210	2150	2270	1102	569	120	1015	917	65	754	55	1791	405	28

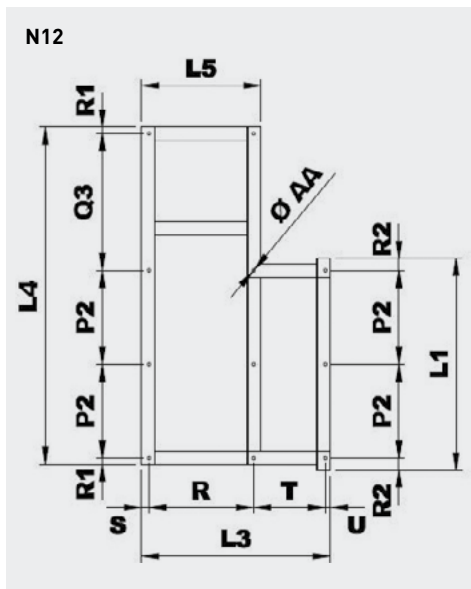

Modelo Model	Bancada ejecución 12 Base frame arrangement 12													Peso Weight (kg)
	P2	L1	L3	L4	L5	Q3	R	R1	R2	S	T	U	Ø AA	
1121 N12A	589	1348	1112	2334	710	1066	600	45	85	55	422	35	24	240
1251 N12A	655	1480	1241	2630	800	1230	710	45	85	45	451	35	24	256
1401 N12A	725	1640	1419	2800	890	1240	780	55	95	55	549	35	24	270
1601 N12A	820	1850	1655	2945	1047	1195	917	55	105	65	928	45	28	350
1801 N12A	915	2070	1729	3245	1047	1295	917	60	120	65	692	55	28	-
2001 N12A	1015	2270	1791	3500	1047	1350	917	60	120	65	754	55	28	-

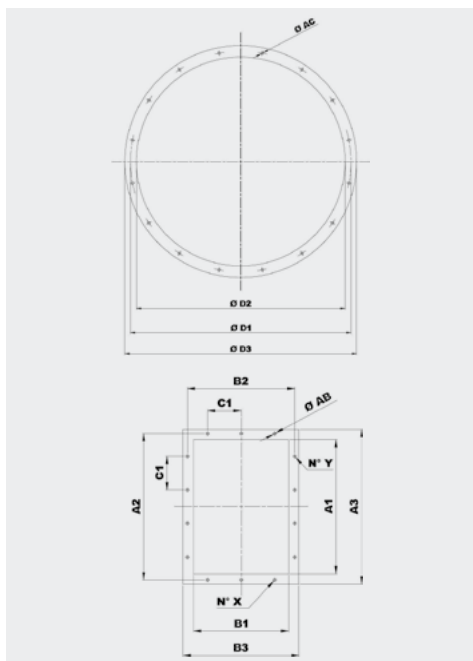

Modelo Model	Brida aspiración Inlet flange					
	Tipo brida Bride type	Ø D1	Ø D2	Ø D3	Ø AC	Agujeros Holes
1121	560	629	566	666	10	12
1251	630	698	636	736	10	12
1401	710	775	716	816	12	16
1601	800	861	806	906	12	16
1801	900	958	906	1006	12	16
2001	1000	1067	1007	1107	12	24

Modelo Model	Brida descarga Discharge flange											
	Tipo brida Bride type	A1	B1	A2	B2	A3	B3	C1	Ø AB	N°X	N°Y	
1121	450x315	453	322	497	366	533	402	125	12	3+3	4+4	
1251	500x355	507	361	551	405	587	441	125	12	3+3	4+4	
1401	560x400	569	404	629	464	669	504	160	14	3+3	4+4	
1601	630x450	638	453	698	513	738	553	160	14	3+3	4+4	
1801	710x500	715	507	775	567	815	607	160	14	3+3	5+5	
2001	800x560	801	569	871	639	921	689	200	14	3+3	4+4	

AMORTIGUADORES / SILENT BLOCKS

Amortiguadores recomendados / Suggested silent blocks		
Ventilador / Fan	Ejecución 9 / Arrangement 9	Ejecución 12 / Arrangement 12
351/2	4 x AM 25 - 25 x 20	4 x AM 30 - 30 x 30
401/2	4 x AM 30 - 30 x 30	4 x AM 30 - 30 x 30
451/2	4 x AM 30 - 30 x 30	4 x AM 40 - 40 x 30
501/2	4 x AM 40 - 40 x 30	4 x AM 50 - 50 x 40
561/2	4 x AM 50 - 50 x 40	4 x AM 50 - 50 x 40
631/2	4 x AM 50 - 50 x 40	4 x AM 75 - 75 x 50
711/2	4 x AM 75 - 75 x 50	4 x AM 75 - 75 x 50
801/2	4 x AM 75 - 75 x 50	4 x AZ 39 - 140 x 39
901/2	4 x AZ 39 - 140 x 39	4 x AZ 39 - 140 x 39
1001/2	4 x AZ 39 - 140 x 39	4 x AZ 39 - 140 x 39
1121	6 x AZ 39 - 140 x 39	6 x AZ 51 - 132 x 51
1251	6 x AZ 51 - 132 x 51	6 x AZ 51 - 132 x 51
1401	-	6 x AZ 51 - 132 x 51
1601	-	6 x AZ 63 - 150 x 63
1801	-	6 x AZ 63 - 150 x 63
2001	-	6 x AZ 63 - 150 x 63

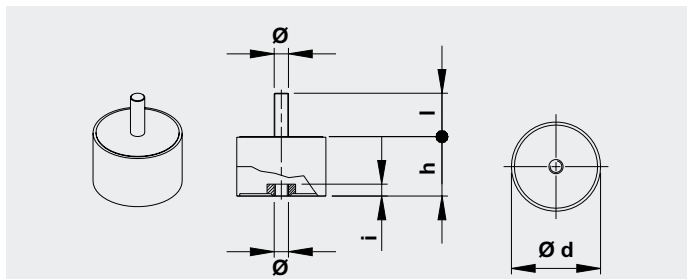

Tipo Type	Carga para 4 soportes Load for 4 supports (kg)	d	h	Ø	l	Peso Weight (kg)
AM25	41÷80	25	20	M6	18	0,03
AM30	81÷140	30	30	M8	20	0,05
AM40	141÷224	40	30	M8	23	0,10
AM50	225÷315	50	40	M10	28	0,20
AM75	316÷630	75	50	M12	37	0,50

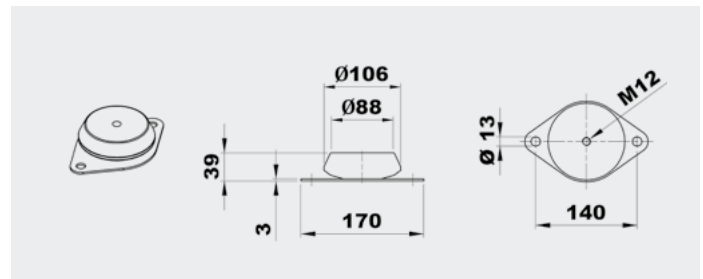

Tipo Type	Carga para 4 soportes Load for 4 supports (kg)	Peso Weight (kg)
AZ 39	631÷1250	0,7

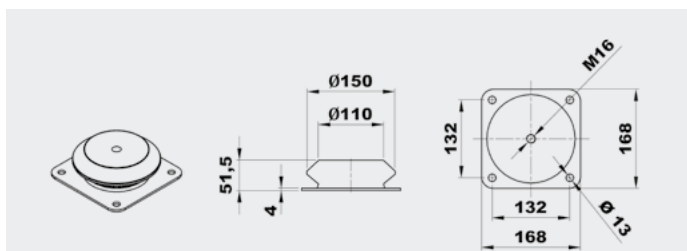

Tipo Type	Carga para 4 soportes Load for 4 supports (kg)	Peso Weight (kg)
AZ 51	1251÷2500	1,8

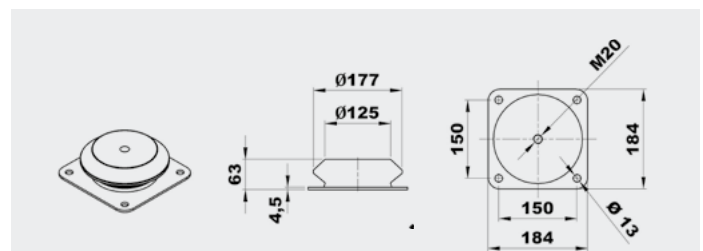

Tipo Type	Carga para 4 soportes Load for 4 supports (kg)	Peso Weight (kg)
AZ 63	2501÷5000	2,5

ACCESORIOS / ACCESSORIES

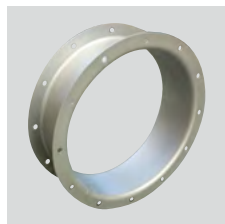

CA (CFH1) - CFH2 - CFH3
 Contrabrida -
 Brida plana circular.
*Counter-flange -
 Circular flange.*

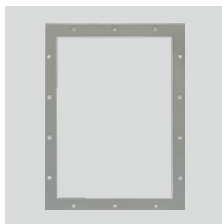

CP
 Brida plana
 rectangular.
Rectangular Flange.

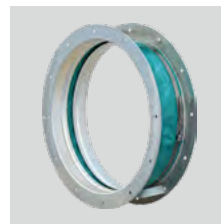

GA
 Junta flexible
 aspiración.
*Inlet flexible
 connector.*



GP
 Junta flexible
 descarga.
*Outlet flexible
 connector.*



DP
 Regulador de caudal
 de aspiración.
*Inlet damper
 governor.*



SAD
 Compuerta de
 regulación de caudal
 de descarga.
*Air reducing damper
 at outlet.*



SF
 Vávula mariposa.
Throttle valve.



DF
 Filtro en la
 aspiración.
Air filter at inlet.

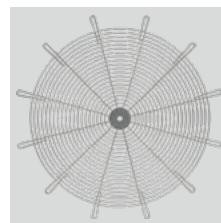

RC
 Rejilla de protección
 para la aspiración.
Protection net.



AM/AZ
 Soportes
 antivibratorios.
Silent blocks.



SCSO
 Silenciador
 cilíndrico.
*Cylindrical sound
 attenuator.*



SCCO
 Silenciador cilíndrico
 con bulbo.
*Cylindrical sound
 attenuator with
 internal pot.*

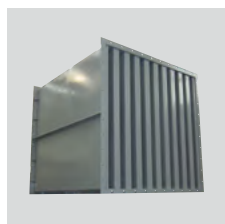

SASS
 Silenciador
 rectangular.
*Baffle type sound
 attenuator.*

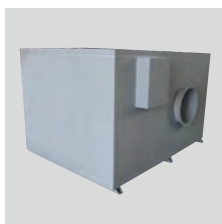

CI
 Cabina de
 insonorización.
Noise enclosure.

Ver información completa en "Accesorios de montaje".
 For more information see "Mounting accessories".